

# **A COUNTERFEIT COMPONENT CASE HISTORY**

**Bob Lowry**

**Electronic Materials Consultant**

**3000 Purple Martin Lane**

**Indialantic, FL**

**321-777-9949**

**rlowry98@aol.com**

**A SORDID TALE OF NEGLECTED PRODUCT QUALITY,  
DRIVEN BY AVARICE AND SCHEDULE**

**Final System  
Builder**

**Sub-System  
Builder**

**Board  
Assembler**

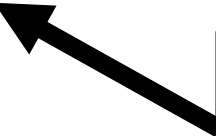

**ONCE UPON A TIME,  
LONG LONG AGO,  
THERE WAS.....**

Transistors

**Final System  
Builder**

**Sub-System  
Builder**

**Board  
Assembler**

**OCM 2**

**OCM 1**

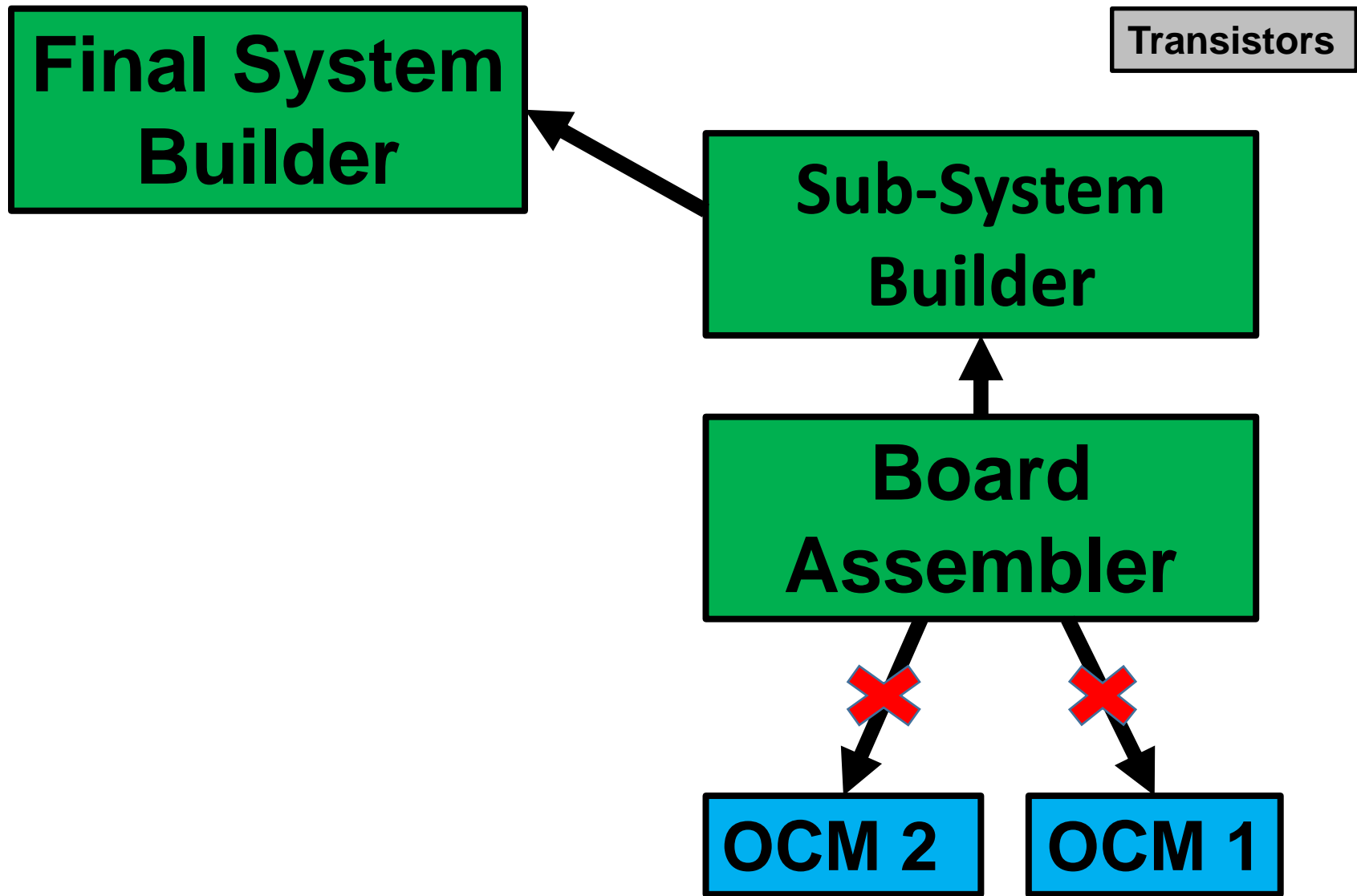

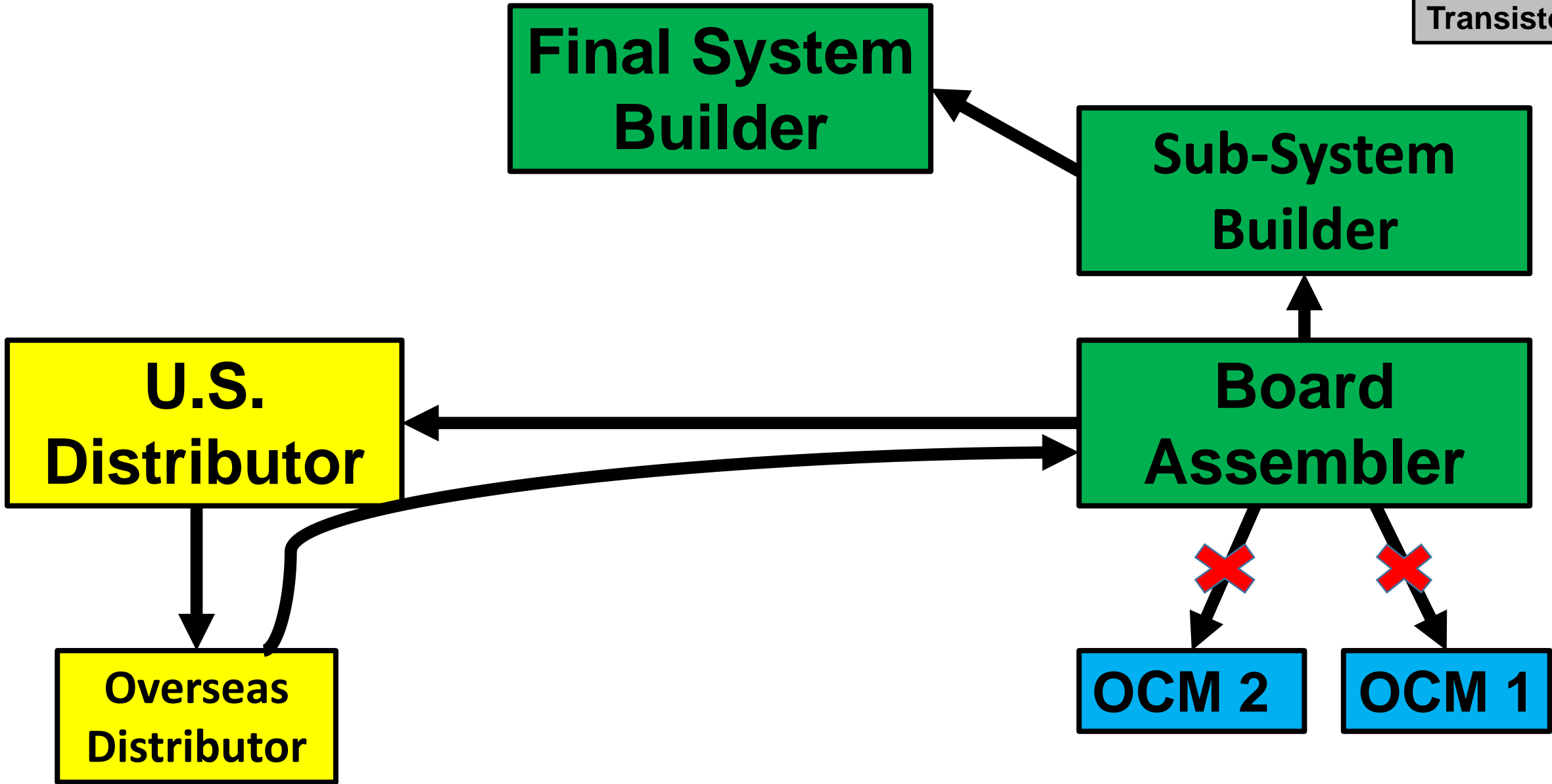

Transistors

**Final System Builder**

**Sub-System Builder**

**Board Assembler**

**U.S. Distributor**

**Overseas Distributor**

**NO PAPERWORK!**

**OCM 2**

**OCM 1**

Transistors

**Final System Builder**

**Sub-System Builder**

**Board Assembler**

**U.S. Distributor**

**Overseas Distributor**

20%  
Lab 1

**OCM 2**

**OCM 1**

Transistors

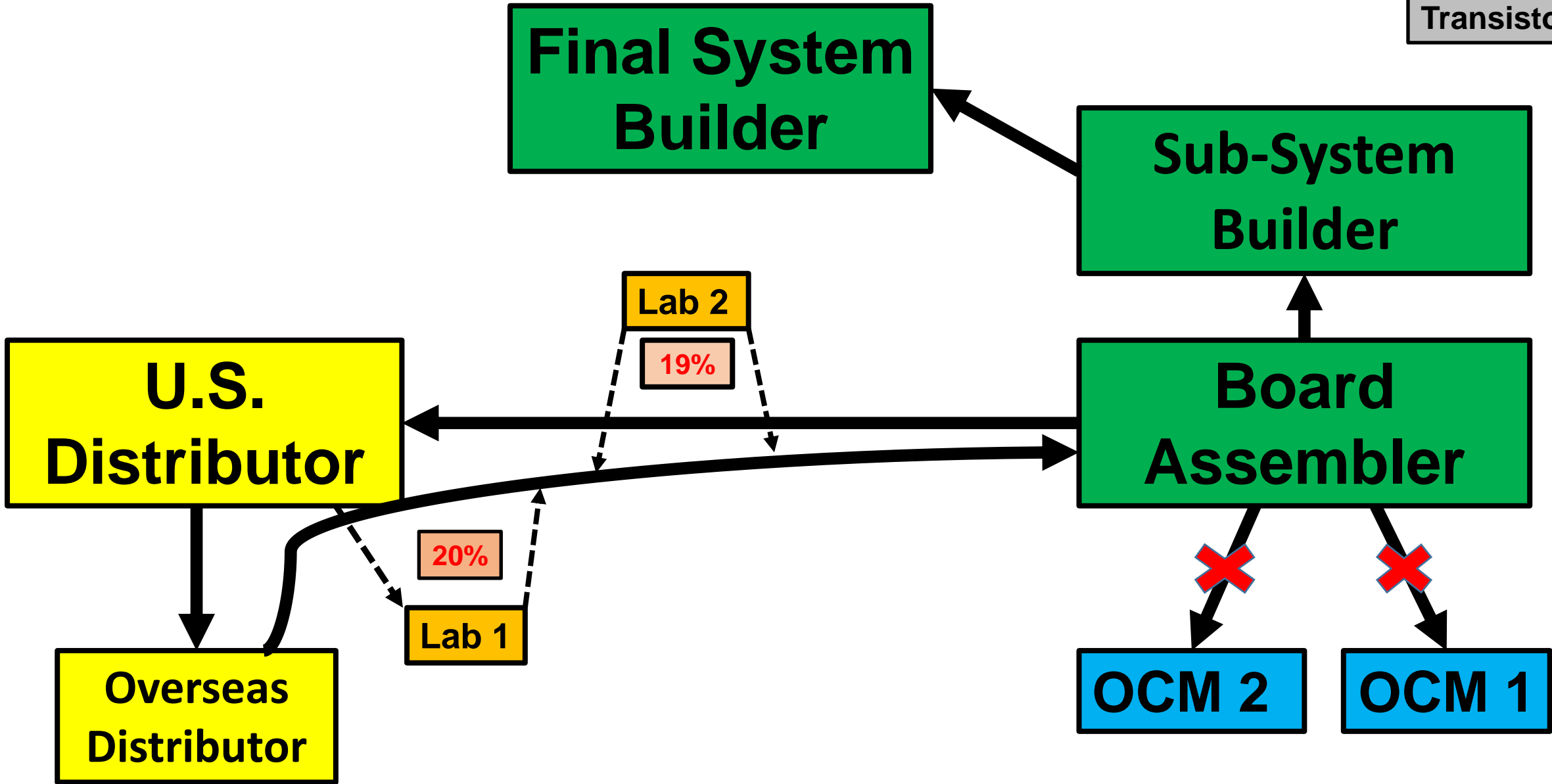

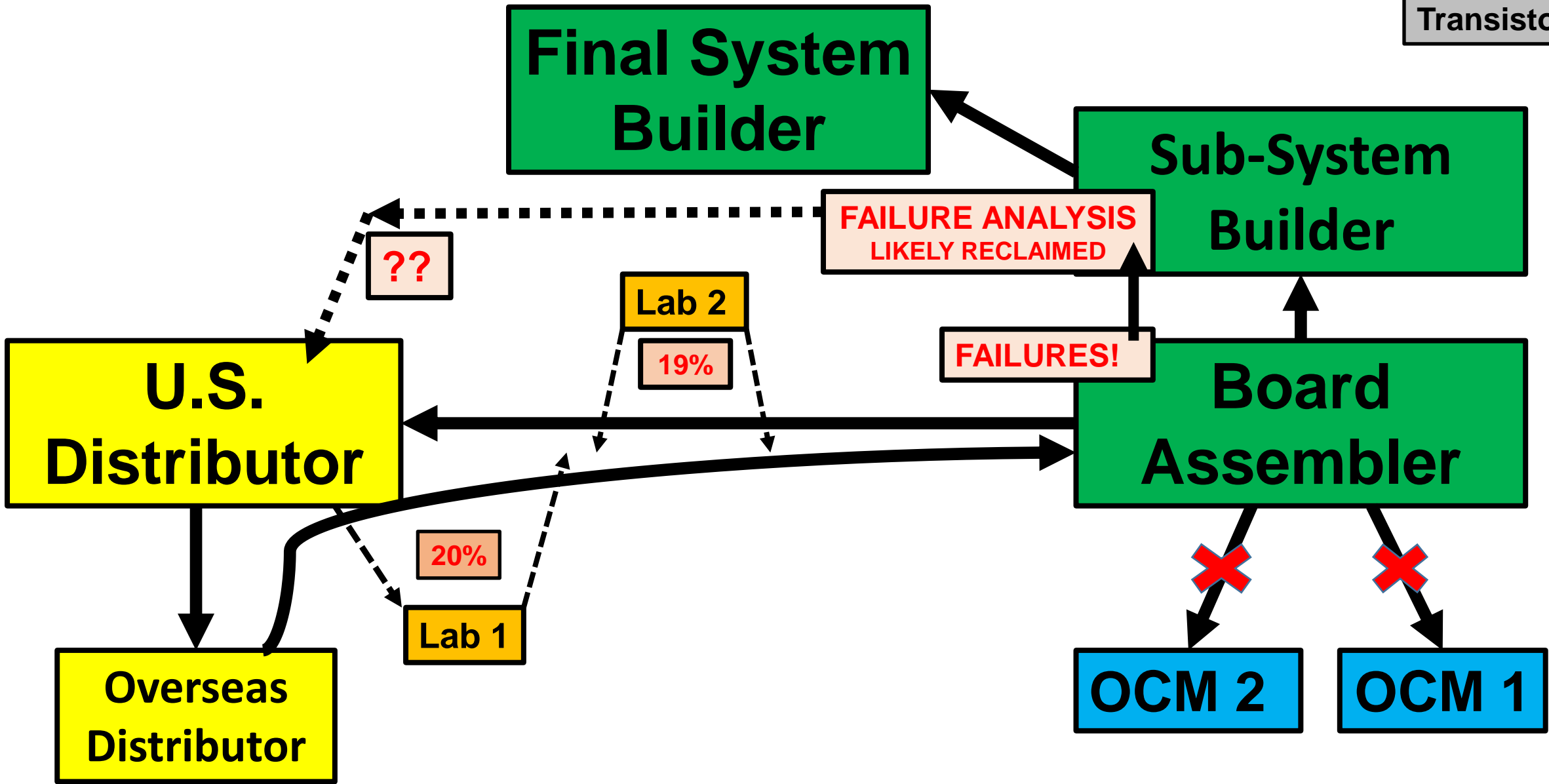



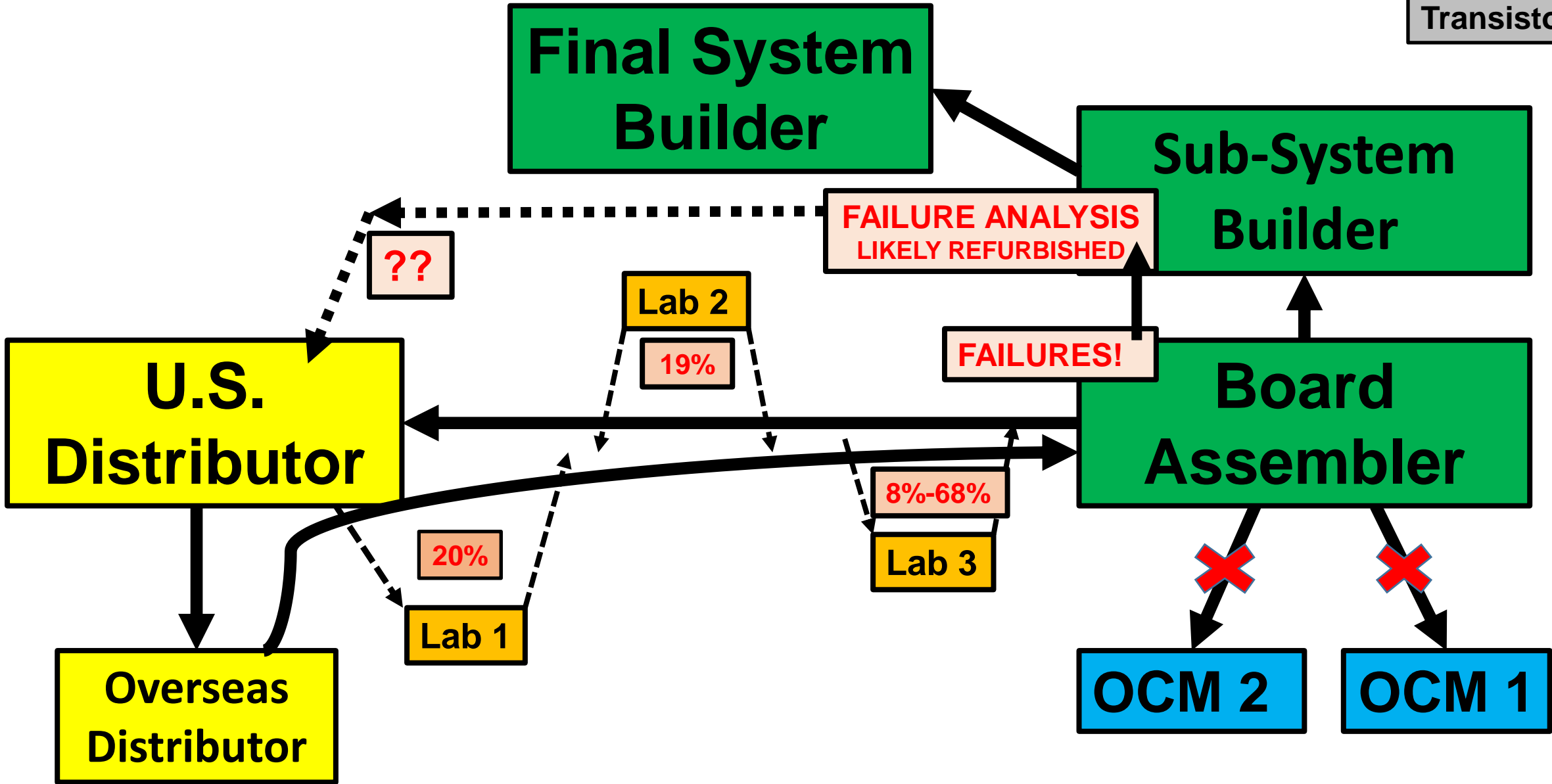

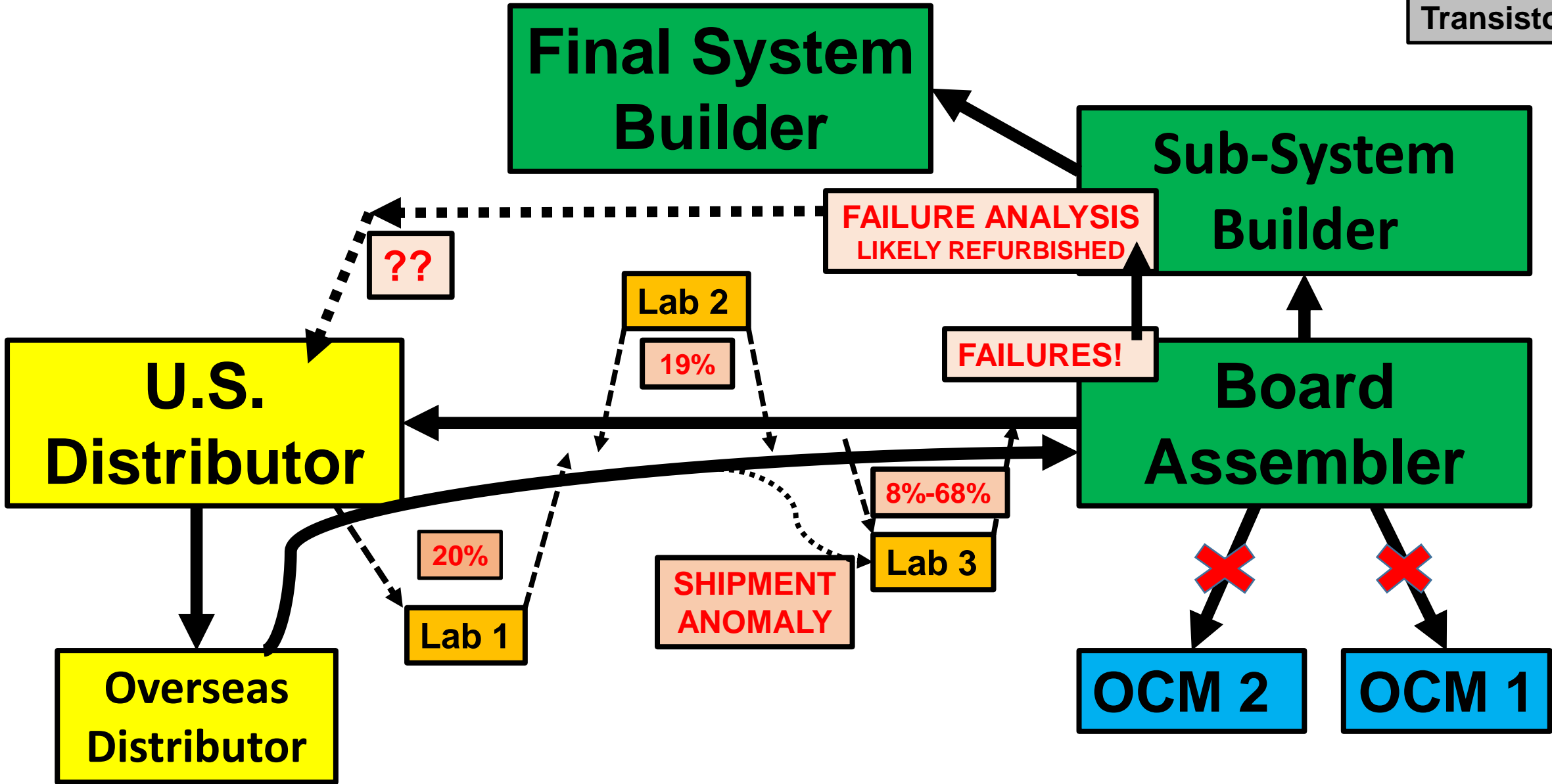

**PRODUCT FOR GROUP A  
ELECTRICAL TESTING ARRIVED  
IN THIS BOX**

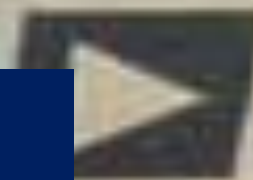

**ANALOG  
DEVICES**

# PRODUCT INSIDE THE BOX...



Transistors

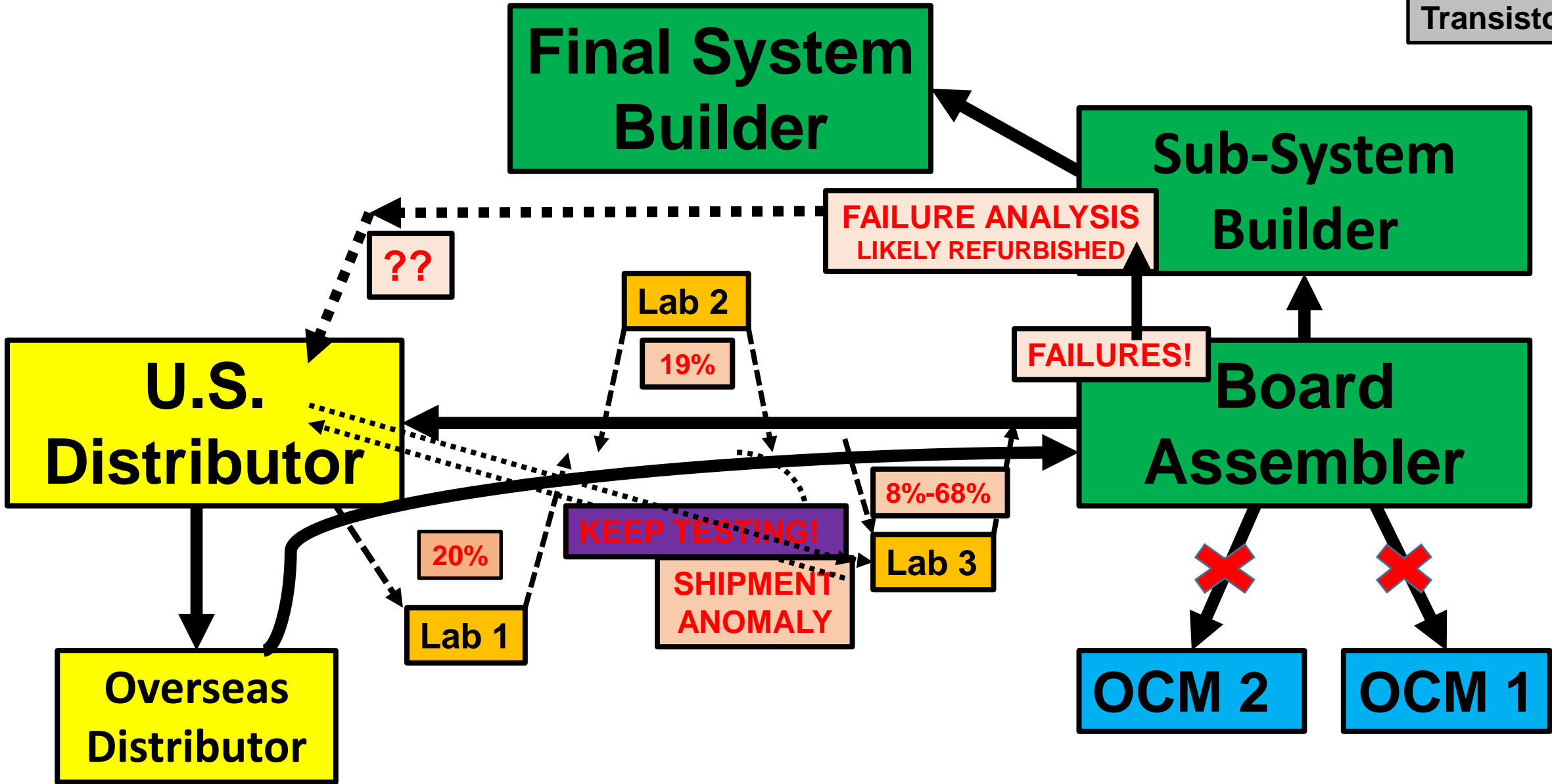

Transistors

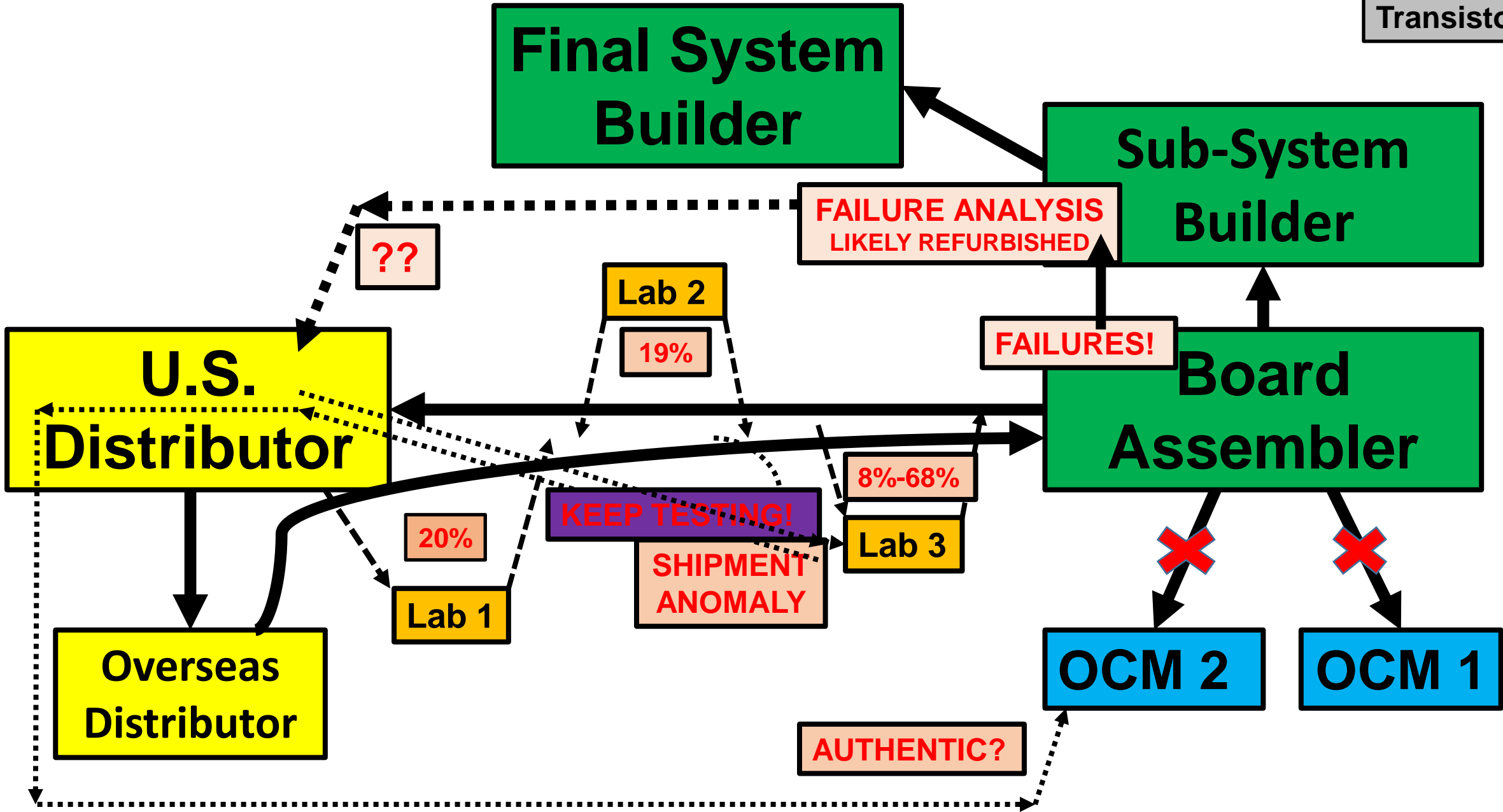

Transistors

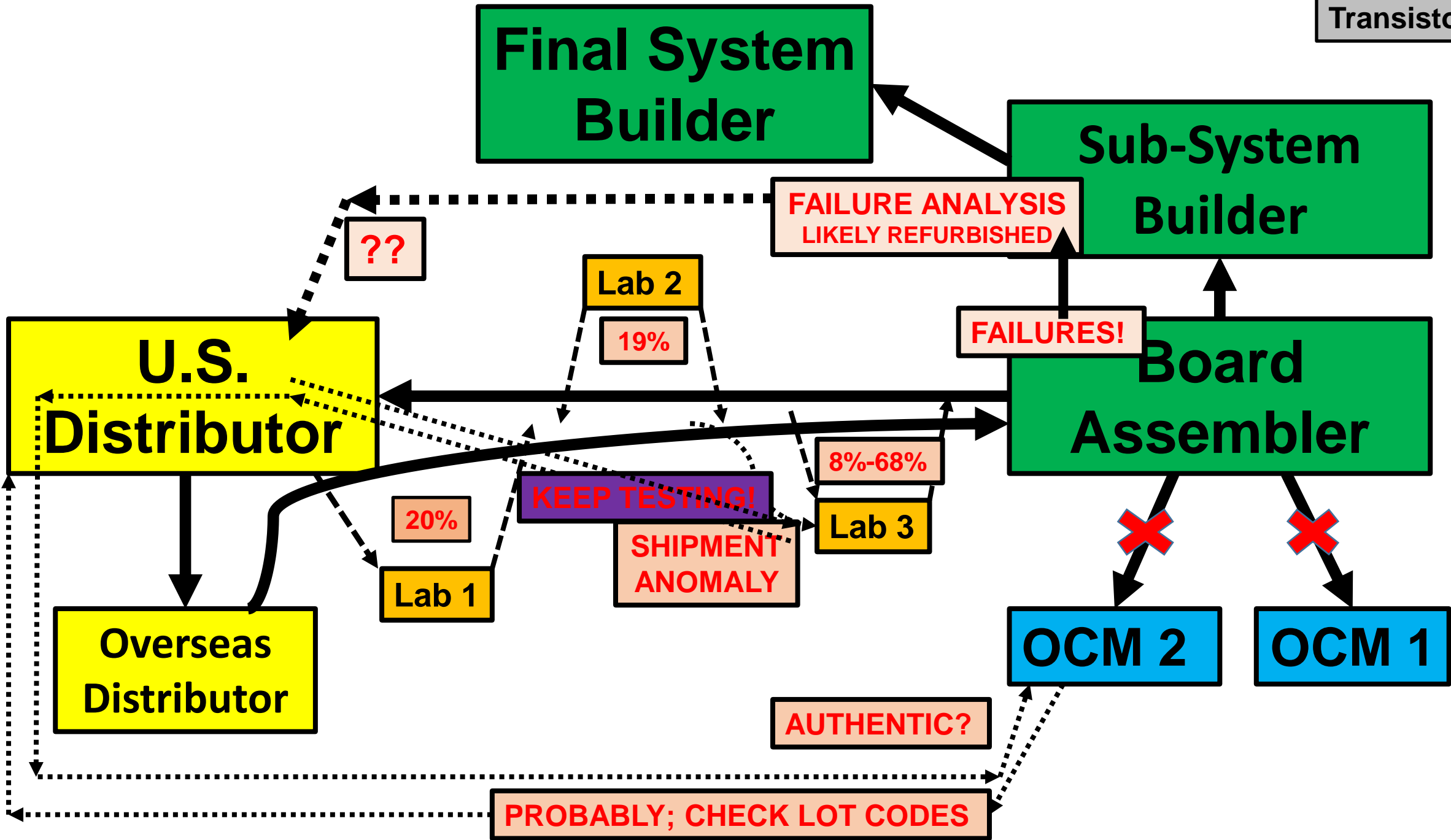

Transistors

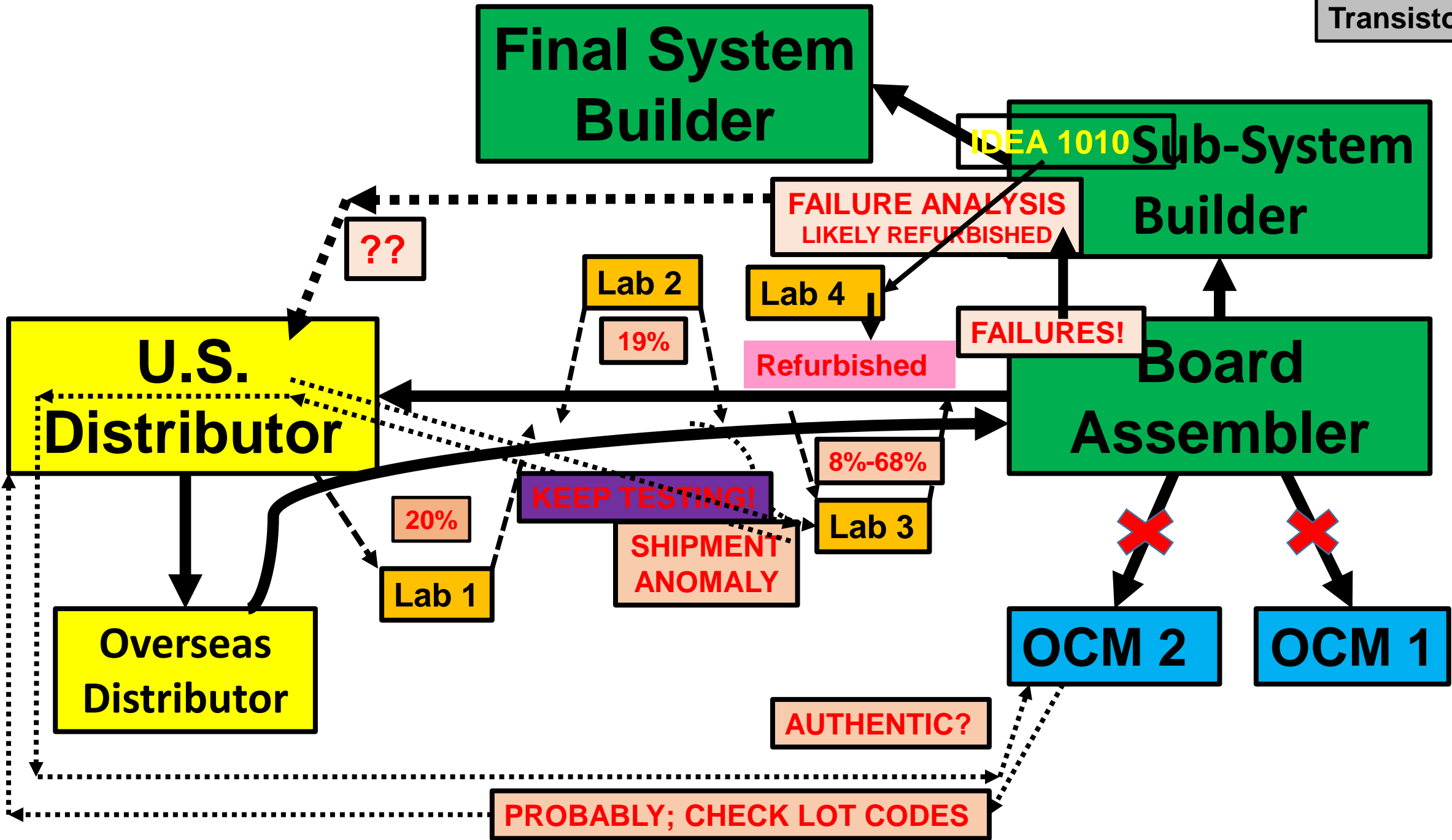



Transistors



**Final System Builder**

**Sub-System Builder**

**Board Assembler**

**U.S. Distributor**

**Overseas Distributor**

**OCM 2**

**OCM 1**

FAILURE ANALYSIS  
LIKELY REFRUBISHED

REFURB FAILURES!

??

Lab 2

19%

Lab 4

REFURB

**LITIGATION!!**

8%-68%

Lab 3

20%

Lab 1

KEEP

SHIPMENT ANOMALY

X

X

AUTHENTIC?

PROBABLY; CHECK LOT CODES

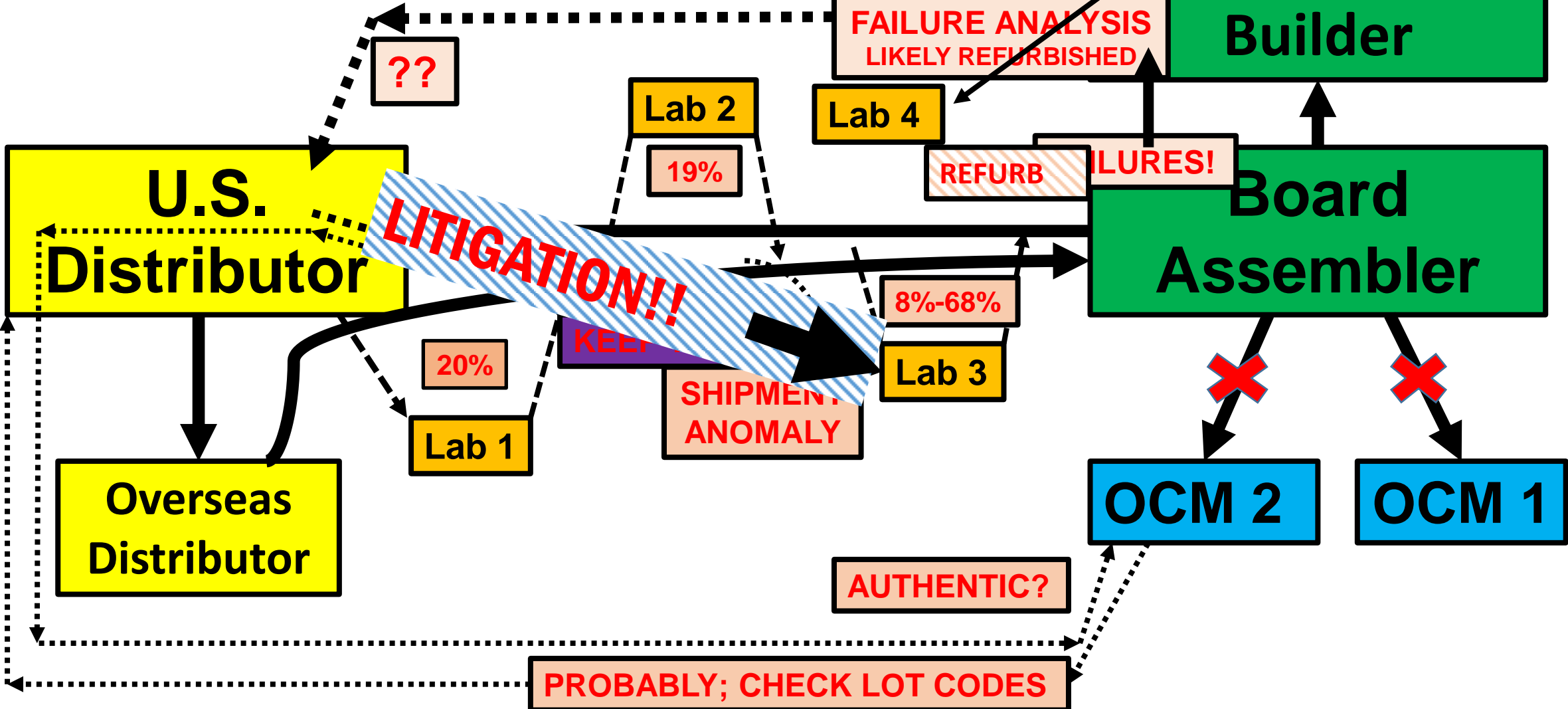

# **LITIGATION: DISTRIBUTOR v. LAB 3**

- **Distributor requested quote for Group A electrical testing.**
- **Lab provided quote solely for Group A electrical testing.**
- **Distributor provided purchase order specifying Group A electrical testing.**
- **Distributor sued Lab 3 for not conducting IDEA-Std-1010 inspection.**
- **No inspection for authenticity was part of request for quote, the quote provided, or the purchase order (a binding contract) issued.**

Transistors



**Final System**

**Sub-System Builder**

**Board Assembler**

**U.S. Distributor**

**Overseas Distributor**

**OCM 2**

**OCM 1**

**HELPED WRITE - HAD TRAINED INSPECTORS**

**IDEA 1010**

**FAILURE ANALYSIS  
LIKELY REFINISHED**

**FAILURES!**

**??**

**Lab 2**

**19%**

**Lab 4a**

**Auth**

**Lab 4b**

**XXXX**

**LITIGATION!!**

**8%-68%**

**Lab 3**

**20%**

**Lab 1**

**KEEP**

**SHIPMENT  
ANOMALY**

**X**

**X**

**AUTHENTIC?**

**PROBABLY; CHECK LOT CODES**

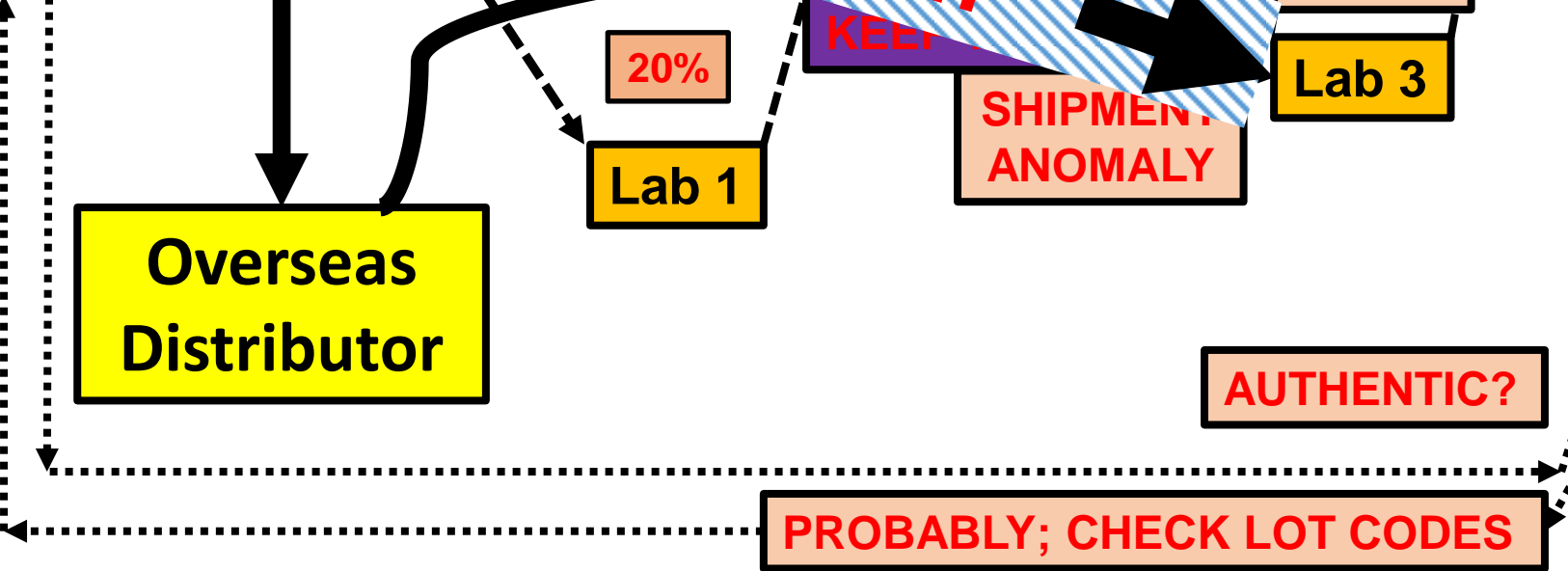
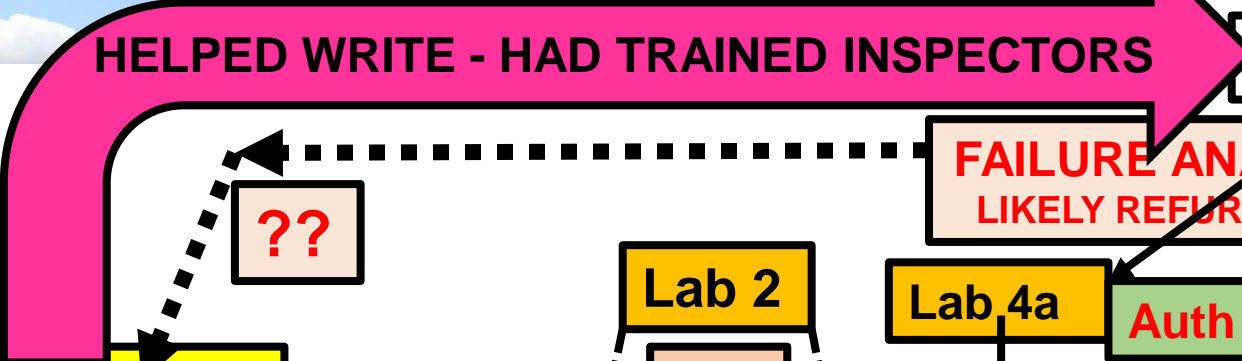



# QUALITY RED FLAGS



**There was no concern for quality in the relationship between the Distributor and the Board Assembler!**



**Goods sourced from China**



**Product shipments with no paperwork**



**Lab 1, 20% Group A electrical fail rate**



**Lab 2, 19% Group A electrical fail rate**



**Visual inspection failures: bent leads, oxidized leads, cracked glass**



**Board failures, FA showed transistors re-furbished**



**Lab 3, 8%-68% Group A electrical fail rate**



**IR goods in AD boxes**



**Disregard of PDA guidelines in Mil 19500**

# DRIVERS

**DISTRIBUTOR**

**PROFIT**

**(340%+ MARGIN)**

**SYSTEM BUILDER**

**SCHEDULE**

.....

**DON'T LET AVARICE OR SCHEDULE TRAP YOU INTO USING  
COUNTERFEIT DEVICES: DO DUE DILIGENCE**

-----

- **AVOID NON-AUTHORIZED DISTRIBUTORS**
  - **GET OCM TRACEABILITY**
  - **USE DMS RESOURCES**
- **RUTHLESSLY INSPECT: DOCUMENTS, CARTONS, DEVICES**