

# Microelectronics: Critical Enabler for Innovation

- ▶ CMSE 2026 Keynote
- ▶ Dev Shenoy, Ph.D.
- ▶ Strategic Advisor
- ▶ IBM Semiconductors/  
IBM Research

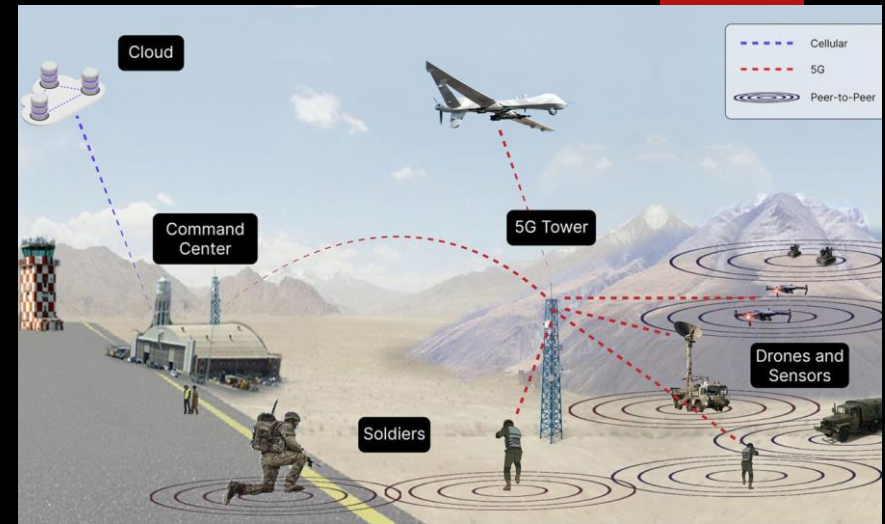

# SHARED INNOVATION: DUAL USE TECHNOLOGY

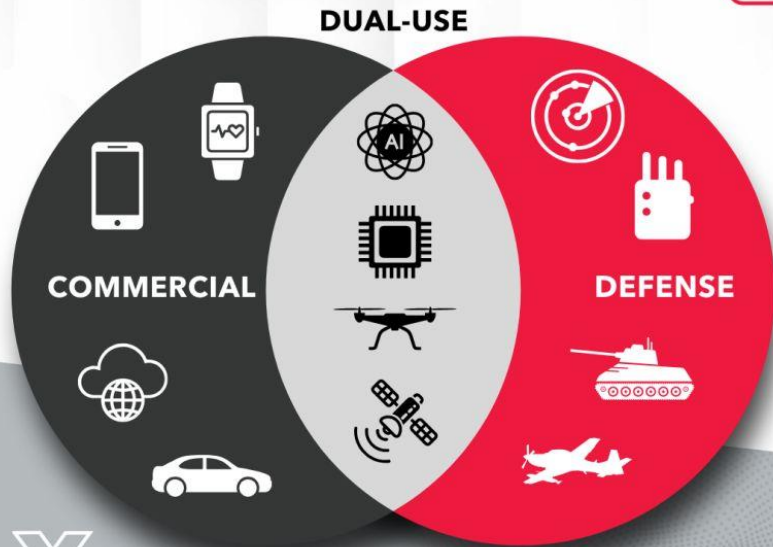

## Overview

- Importance of microelectronics
- Commercial vs military needs
- U.S. ecosystem and CHIPS Act
- Future opportunities

# Military Requirements

- Harsh environments
- Reliability and longevity
- Security and trust
- Custom (bespoke) solutions



Source: defense news

## The Multidimensional Challenge in Gaining Visibility into the Electromagnetic Spectrum for Electronic Warfare

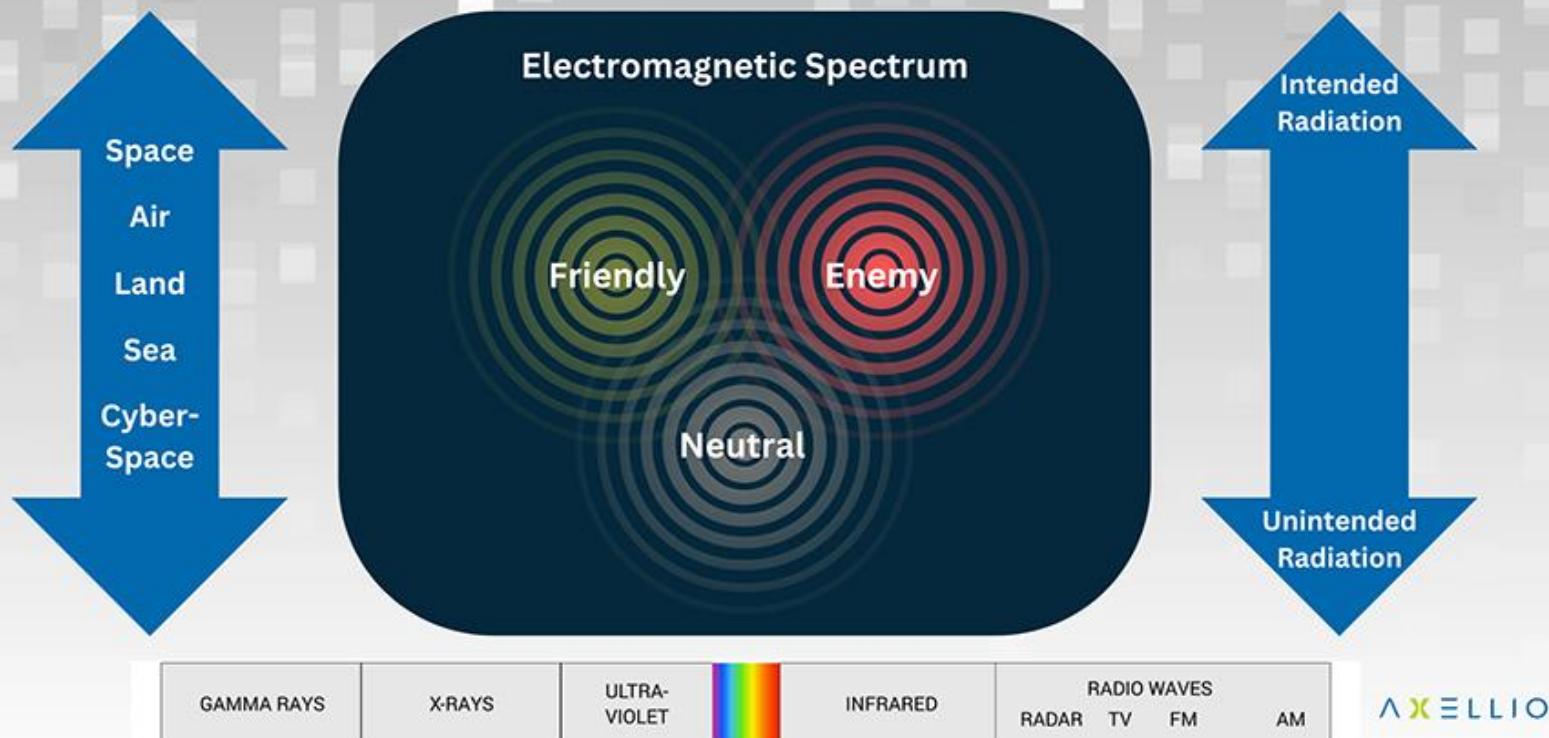

## Asymmetric Capabilities

- Advanced microelectronics enable battlefield advantage
- AI-driven decision systems
- Electronic warfare superiority

# High-reliability Semiconductors for Aerospace & Defense Market: 2019-2027

- North America
- Europe
- Asia Pacific
- Middle East & Africa
- South America

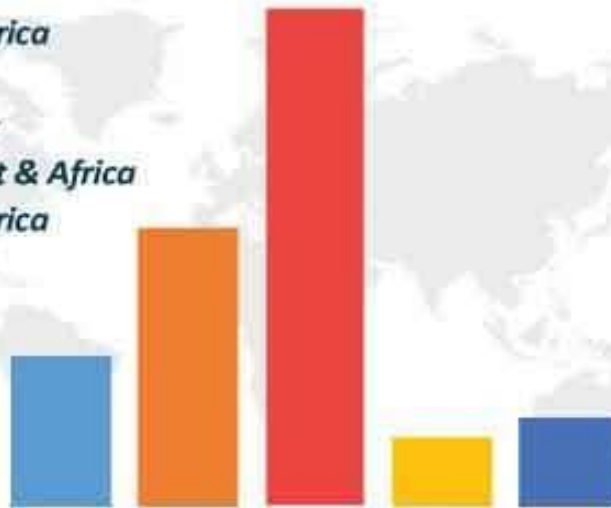

**~5% CAGR (2019-2027)**

Market Value

~US\$ **8.6 Bn** (2027)

• Key Market Driver •



Impedance-matched Amplifiers Deliver Robust Performance in Satellites and Avionic Systems

• Key Market Restraint •



Vulnerabilities of ICs Lead to Premature Failure of Systems in Defense Landscape

• Type •



• Application •

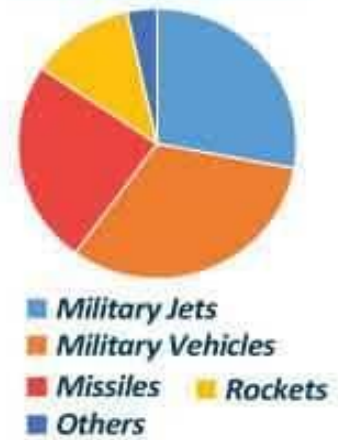

- Backbone of modern systems
- Enables computing, communication, sensing
- Present in all defense and commercial platforms

# Balancing Cost of Test vs Cost of Yield vs. Cost of Failure

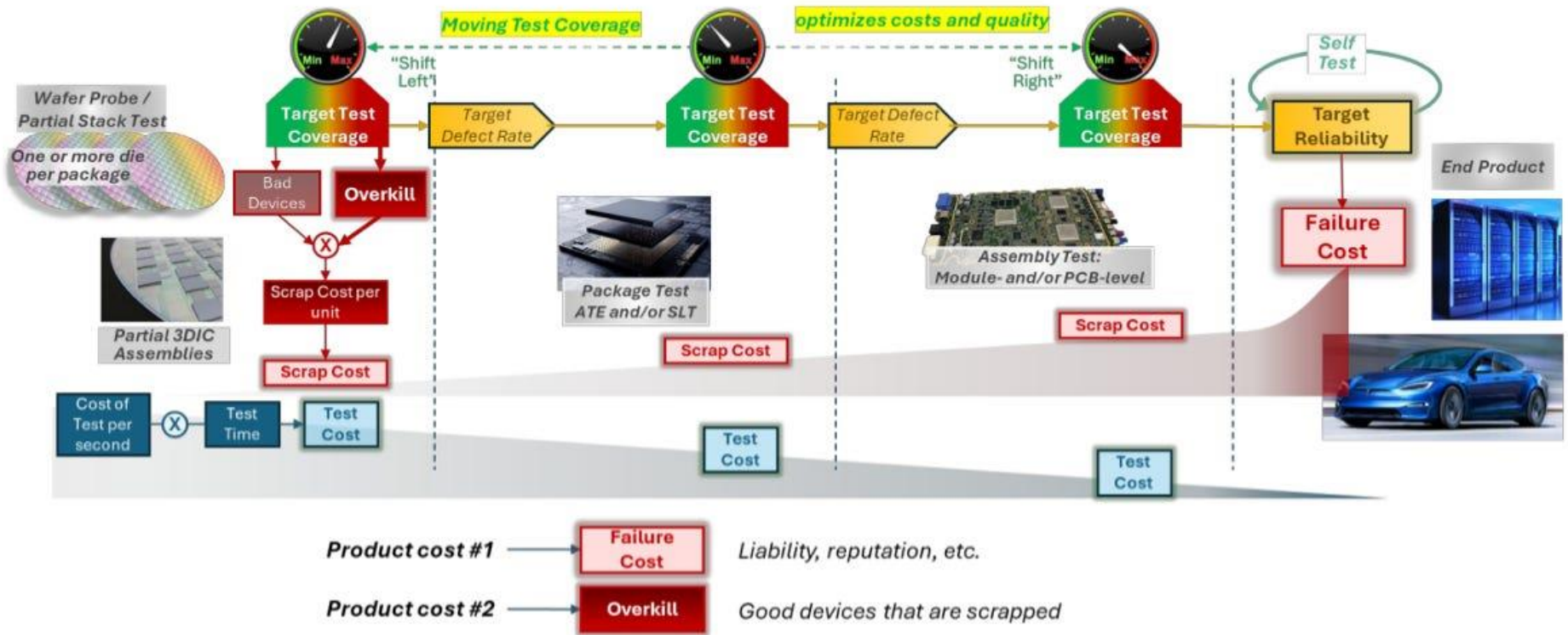

## Future Vision

- Resilient domestic ecosystem
- Faster innovation cycles
- Dual-use technologies



# Commercial Innovation

- Drives scale and rapid advancement
- AI, cloud, mobile, automotive
- System-level integration opportunities

**NETHERLANDS** → Controls the chokepoint

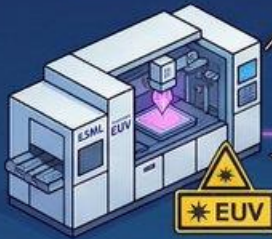

ASML holds ~100% monopoly in EUV lithography

without it, no advanced chips can be made.

# THE GLOBAL SEMICONDUCTOR POWER MAP

**UNITED STATES** → Brain of the ecosystem



~45% of global chip design revenue  
dominates IP, software (EDA), and innovation layer.

**CHINA** → Scale + aggressive catch-up



\$150B+ state push to reduce import dependency focusing on mature nodes & domestic ecosystem.

**INDIA** → Emerging opportunity



designing + camera designing



**INDIA** → Emerging opportunity  
\$100B+ market by 2030

strong design talent + policy push (DLI scheme) aiming to move from design hub → manufacturing ecosystem.

**TAIWAN** → Manufacturing king



~90% of <10nm advanced chip production  
the most critical node in the global supply chain.

**SOUTH KOREA** → Memory powerhouse



~65% global share in DRAM & NAND

backbone of data economy.

## Challenges

- Supply chain fragility
- Cost and complexity
- Talent shortages
- Rapid tech evolution

## Beyond Borders: Semiconductors are a Uniquely Global Industry

Typical semiconductor production process spans multiple countries:

4+ Countries, 4+ States, 3+ trips around the world, 100 days production time



source:chinausfocus

**\$1,511 Billion in Global Trade**

**Top Participants in Global Trade:  
Semiconductor Goods**

China	USA	Viet Nam
Hong Kong	Malaysia	Mexico
Singapore	Japan	Thailand
Taiwan	Germany	France
Korea	Philippines	Netherlands

**\$36.5 Billion in Global Trade**

**Top Participants in Global Trade:  
Fabrication Material Goods**

China	Taiwan	Italy
USA	Singapore	Malaysia
Japan	Mexico	United Kingdom
Germany	Netherlands	France
Rep. of Korea	Norway	Brazil

**\$23.2 Billion in Global Trade**

**Top Participants in Global Trade:  
Assembly, Test, Packaging Goods**

China	Hong Kong	Mexico
Germany	France	United Kingdom
USA	Rep. of Korea	Canada
Japan	Italy	Poland
Taiwan	Netherlands	Belgium

# Manufacturing Renaissance: Semiconductors & Electronics



## Onshore Ecosystem Need

- High-mix, low-volume manufacturing
- Domestic supply chains
- Trusted fabrication and packaging

# About 95 percent of CHIPS Act Fundings Have Gone to Support Semiconductor Fabrication

CHIPS Act fundings by types of companies

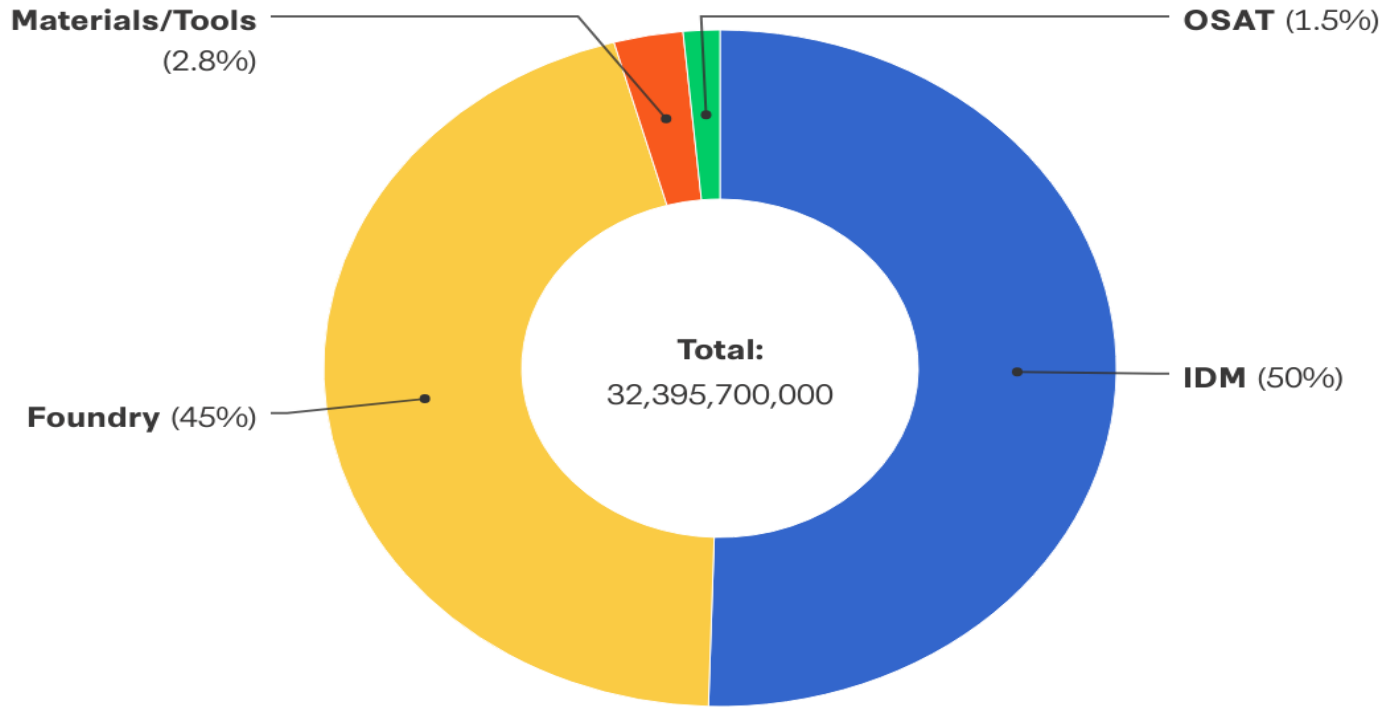

Source: National Institute of Standards and Technology. • Chart: CSIS Renewing American Innovation

CSIS

## CHIPS and Science Act

- Strengthens U.S. semiconductor ecosystem
- Investments in fabs, R&D, workforce
- Public-private partnerships

# MAPT ROADMAP 2.0

Microelectronics and Advanced Packaging Technologies Roadmap



**Advanced Node  
Scaling**  
5nm, 3nm...

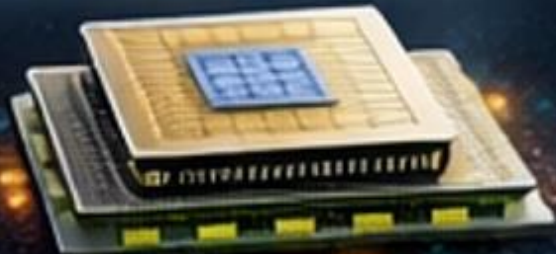

**3D &  
Heterogeneous  
Integration**

**AI Acceleration**



**Quantum  
Computing**



**6G &  
Secure  
IoT**



Microelectronics Technology Trends

# Technology Spectrum

- Leading-edge nodes
- Mature nodes
- Legacy systems
- All critical for defense

## Heterogenous Integration: The Synergy of Different Chip Technologies



AI Servers & Accelerators



Autonomous Driving



5G/6G Base Station

The Core of System-in-Package (SiP) Design

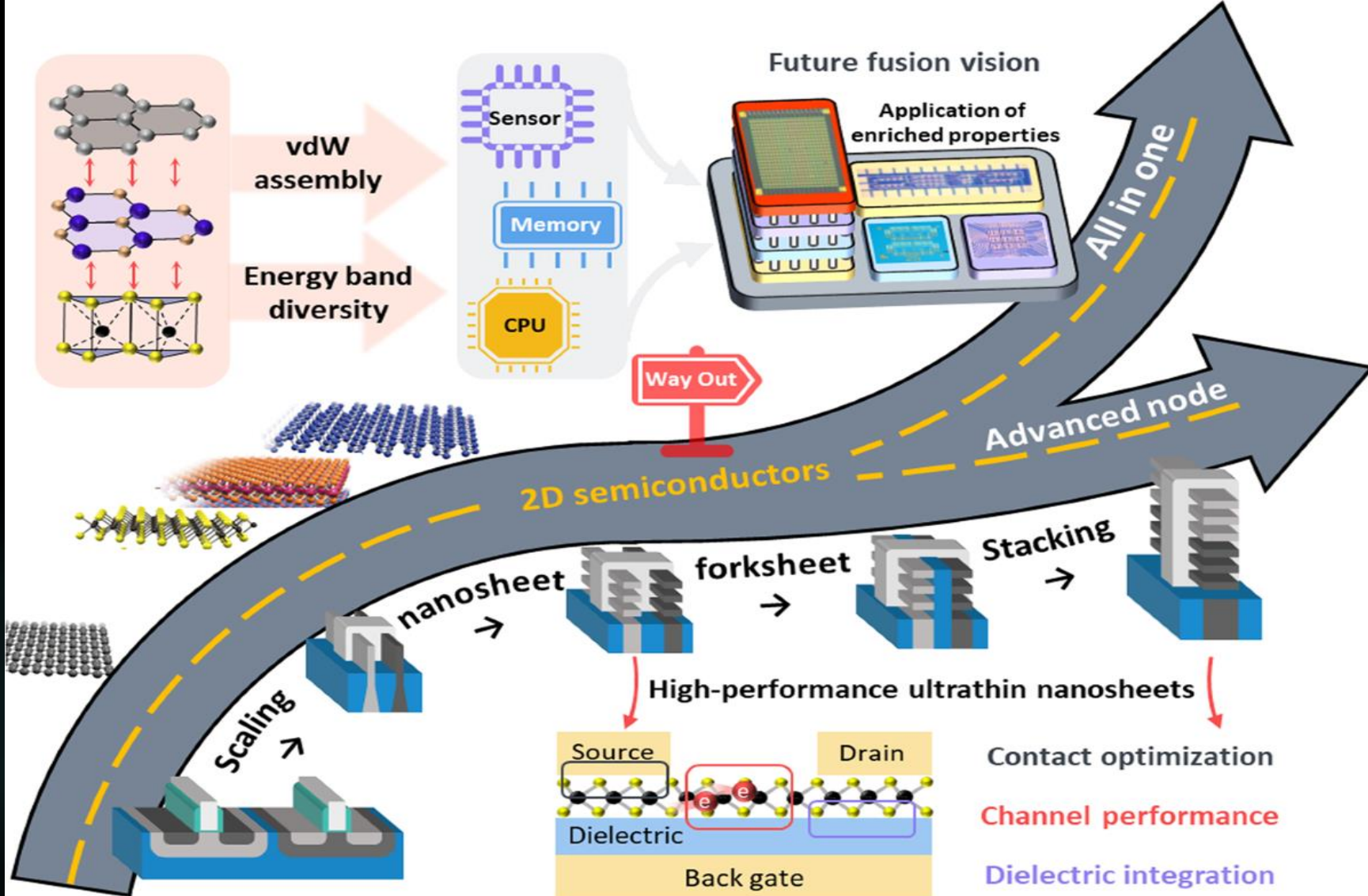

# Materials to Systems

nature

- Materials innovation
- Device engineering
- System integration
- End-to-end optimization

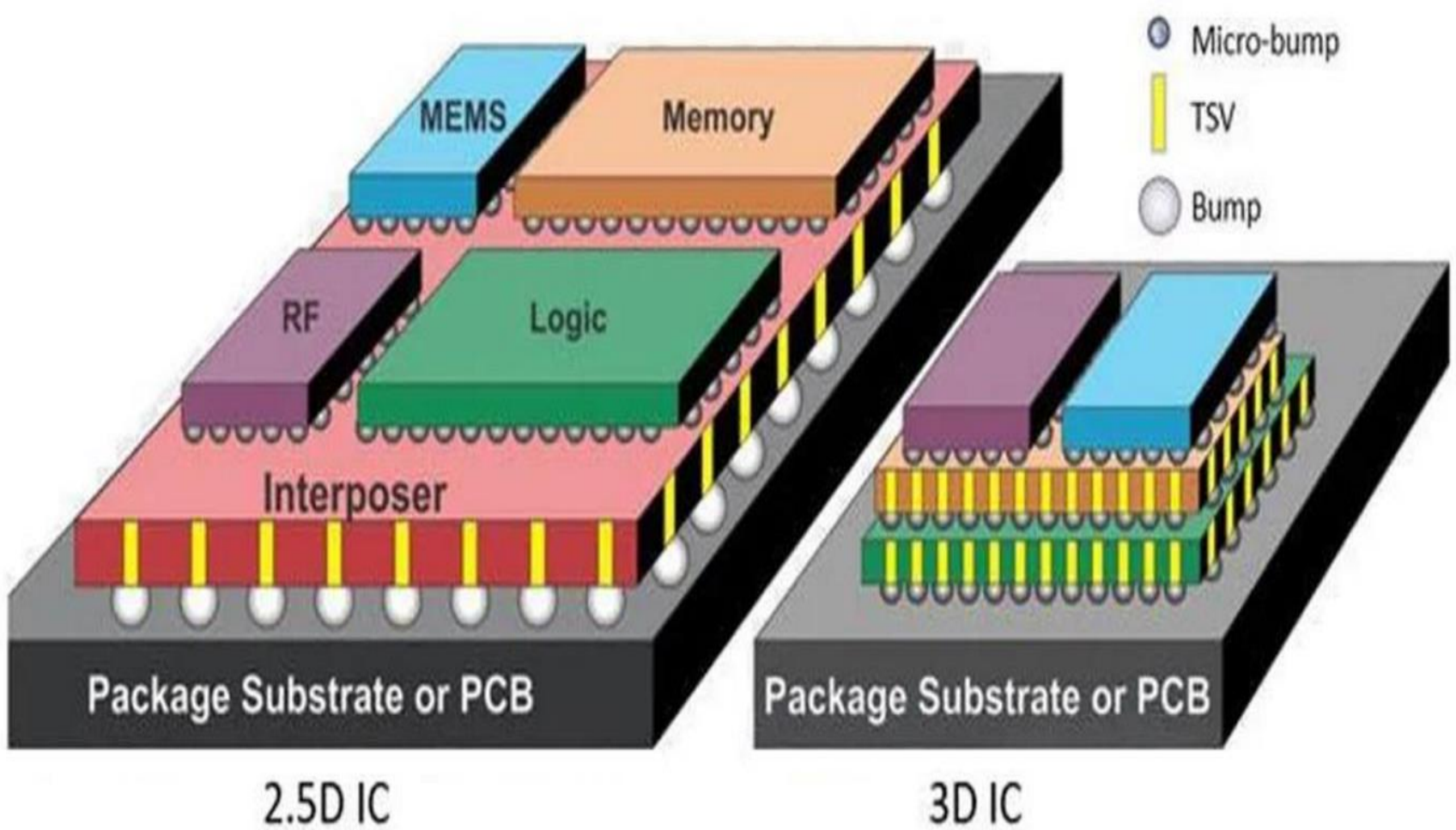

# Opportunities

- Advanced packaging
- Heterogeneous integration
- AI-native hardware
- Secure architectures



# Pre-CHIPS Engagement Activities led to Monumental CHIPS and Science Act



- Joint White Paper with DARPA
- Engagement with the Interagency
- Commons Request for Information (RFI)
- Engagement with Hill and White House
- Congressional Report outlining plan

PUBLIC LAW 116-283—JAN. 1, 2021

WILLIAM M. (MAC)  
THORNBERRY NATIONAL  
DEFENSE AUTHORIZATION  
ACT FOR FISCAL YEAR 2021

## TITLE XCIX—CREATING HELPFUL INCENTIVES TO PRODUCE SEMICONDUCTORS FOR AMERICA

Sec. 9901. Definitions.  
Sec. 9902. Semiconductor incentives.  
Sec. 9903. Department of Defense.

### (b) NATIONAL NETWORK FOR MICROELECTRONICS RESEARCH AND DEVELOPMENT.—

(1) IN GENERAL.—Subject to the availability of appropriations for such purposes, the Secretary of Defense may establish a national network for microelectronics research and development—

(A) to enable the laboratory to fabrication transition of microelectronics innovations in the United States; and  
(B) to expand the global leadership in microelectronics of the United States.

(2) ACTIVITIES.—The national network for microelectronics research and development shall—

(A) enable cost effective exploration of new materials, devices, and architectures, and prototyping in domestic facilities to safeguard domestic intellectual property;

(B) accelerate the transition of new technologies to domestic microelectronics manufacturers; and

(C) conduct other relevant activities deemed necessary by the Secretary of Defense for accomplishing the purposes of the national network for microelectronics research and development.





# December 2023: Microelectronics Commons Call for Projects Released



*Lab-to-fab prototyping bridges valley of death from research to foundry/fab prototyping*

- Critical Technical Areas**
- Electromagnetic Warfare
  - Secure Edge/IoT Computing
  - AI HW at the Edge
  - Quantum Technology
  - Commercial Leap Ahead Technologies
  - 5G/6G



- Application Platforms**
- Aircraft
  - Submarines
  - Ships
  - Space Systems
  - Ground Systems
  - Missile Defense
  - C4ISR



*Projects enhance the value of infrastructure through staffing and utilization of lab and fab facilities*



Distribution Statement A: Approved for public release. Distribution is unlimited.

December 2023  
First Call for Projects (CFP)



# Microelectronics Commons Fills a Key Role in US Microelectronics Initiatives

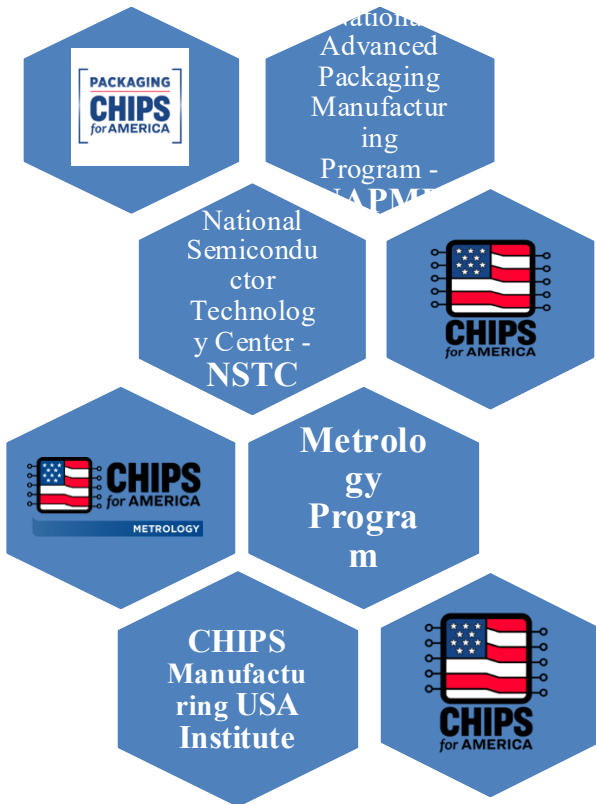

- Accelerates lab-to-fab technology transition
- Reduces reliance on foreign microelectronics and
- Safeguards supply chain risks





# Microelectronics Commons Program

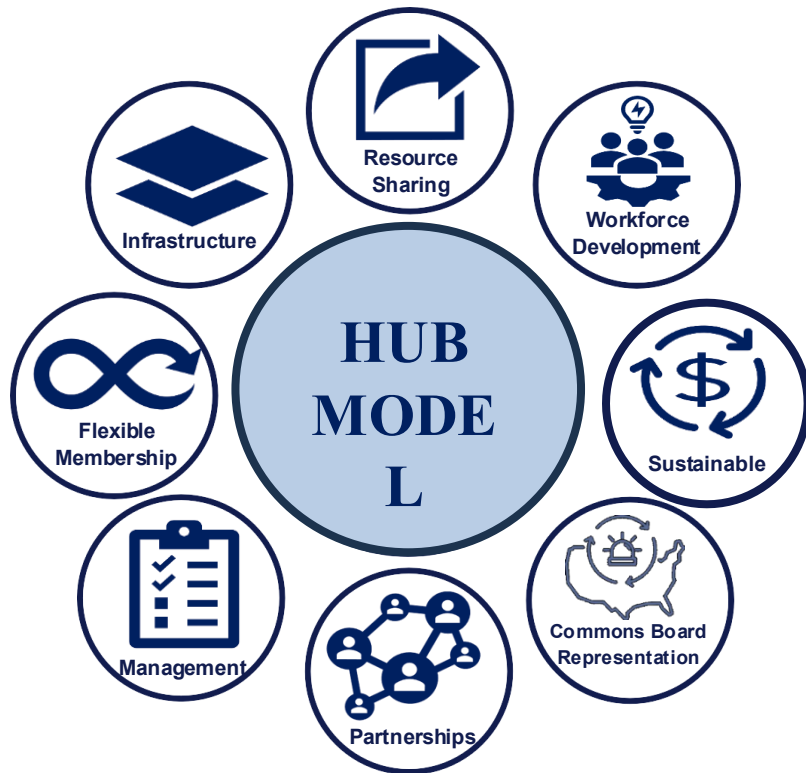

## How is Commons different?

- Onshore Infrastructure Ecosystems
- Democratizing Access
- Enduring Microelectronics Ecosystem for Defense Applications
- Commons Hubs Leverage Regional Strengths
- Collaboration with Allies
- Manufacturing Feasibility for Dual-use

# MANUFACTURING THROUGHOUT THE PRODUCT LIFE CYCLE

Proto Labs is an on-demand manufacturing partner that helps you accelerate product development and strategically manage the entire product life cycle. Get prototypes and low-volume production parts from one supplier, in 15 days or less.

IDEA

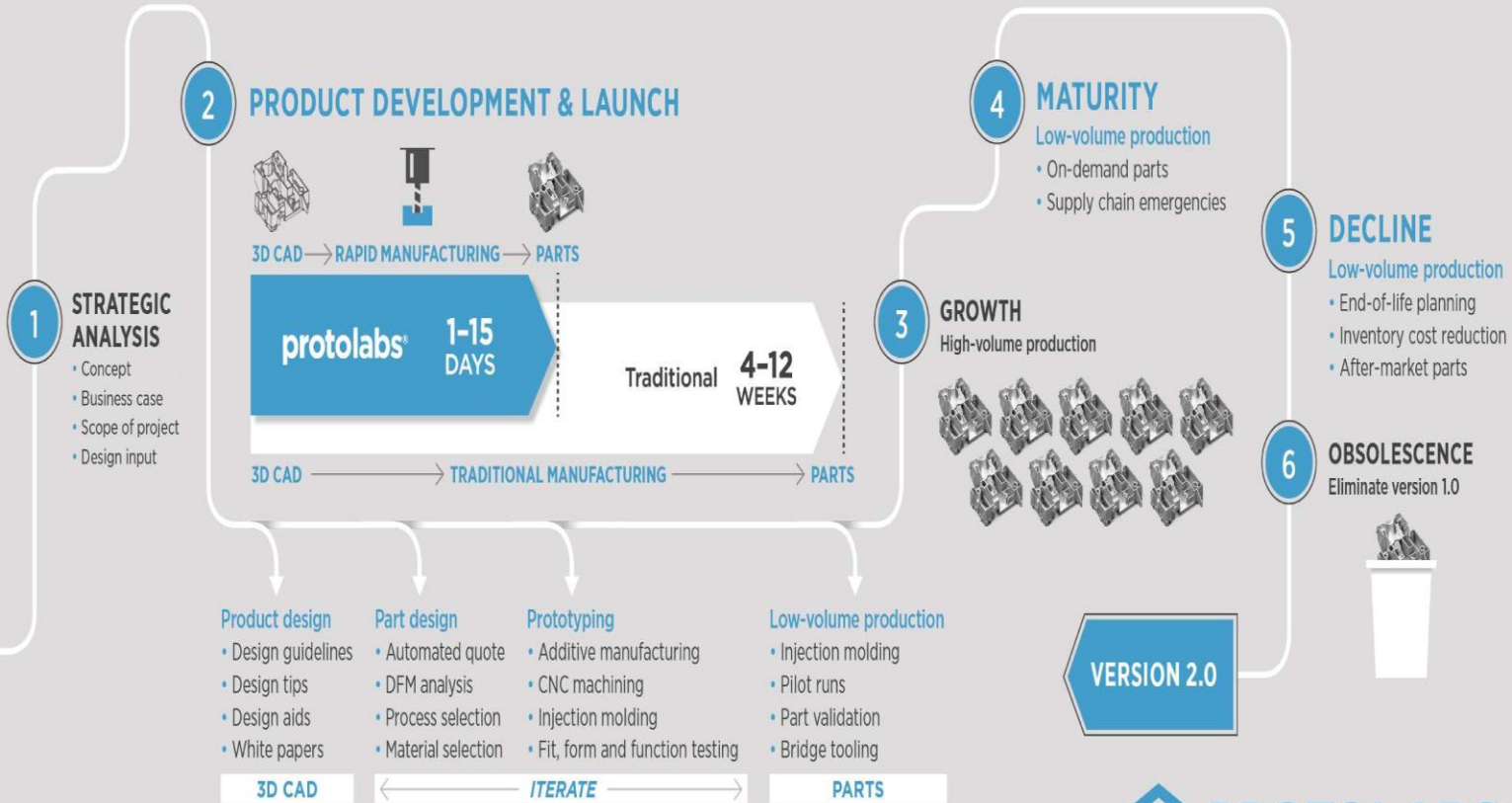

- Democratized design tools, accessible prototyping, faster innovation cycles



Semiconductor  
Research  
Corporation

# A Talent Factory



## Workforce Development

- Training next-gen engineers
- Expanding talent pipelines
- Academia-industry-government collaboration

# The Global Semiconductor Strategy Map

Balancing the Merits of Innovation, Resilience, and Cooperation

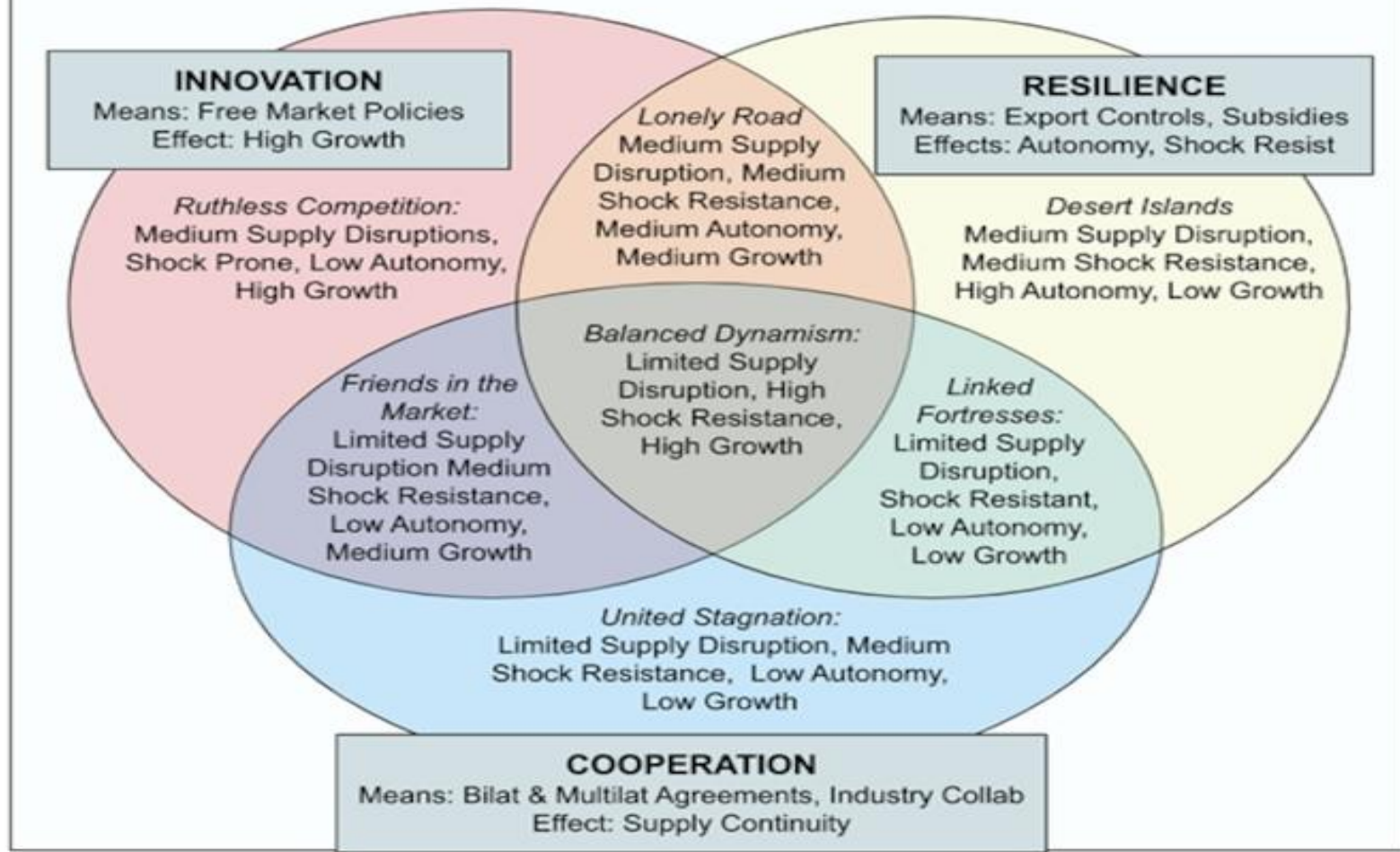

Closing

- ▶ Microelectronics will continue to define the future of both commercial and military systems